



FIGURE 4

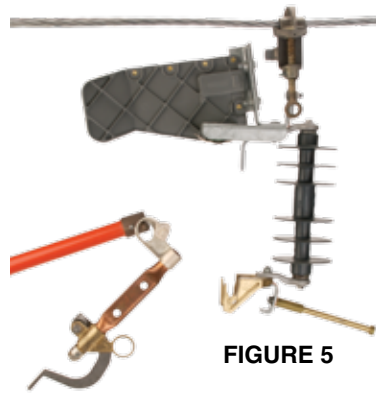

FIGURE 5

Removal

To remove the Temporary Load Disconnect Tool, while maintaining a continuous circuit connection, first make up a permanent connection or replace the previously removed permanent connection, in parallel with the tool. Now there are two energizing paths.

This tool is equipped with an arc-chute type interrupter. The arc chute enables the tool to perform as a loadbreak device capable of interrupting load currents. To operate this loadbreak device, place a disconnect stick in the pull ring on the blade (see Figure 4). Position yourself approximately 2 feet to one side of the tool. Look away from the tool and pull sharply on the disconnect stick without hesitation. After opening blade, swing it into a full open position. Use a disconnect stick to remove the blade from the lower hinge (see Figure 5). With a Grip-All clampstick remove the temporary jumper from the energized conductor and secure it on the stud at the lower hinge. With a Grip-All clampstick remove the tool from the energized line conductor (see Figure 1).

Checklist

1. Check tool for proper closing and latching before each use.
2. This product should not be installed for extended periods. With the blade removed, the insulator may permit excessive leakage depending upon surface contamination and the extent of surface wetting. Wiping the insulator with a clean Chance Wiping Cloth (Cat. No. M1904) or a silicone material will help resist this condition.
3. To assure proper closing and opening operations, always close the blade in line with the insulator.
4. When attaching jumper clamp to load, do not pull tool out of vertical position.
5. Inspect contacts for excessive pitting or burning and replace as necessary. Check blade for burrs or excessive erosion and replace if necessary. Check arc chute for cracks and replace if broken.
6. When not in use or when in storage, **always** keep tool in the storage case provided.
7. After approximately 50 operations, inspect the entire tool as described in Item 5 above.

NOTE: Because Hubbell has a policy of continuous product improvement, we reserve the right to change design and specifications without notice.

©Copyright 2007 Hubbell Power Systems, Inc.

Printed in USA

P6002400
Rev. A

OPERATING INSTRUCTIONS FOR



Temporary Load Disconnect Tool

Catalog No.
PSC6010347
PSC6010348

Application
8.3/15kV
15/27kV

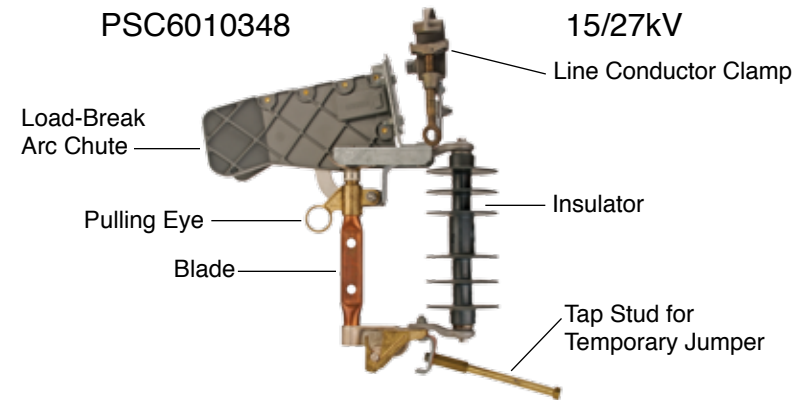

This unfused tool provides a temporary means of connecting and disconnecting equipment or circuits under load conditions. This tool does not provide fault or overcurrent protection. It has no fuse. It should never be closed into a fault or opened during a fault. Unfused or unswitched loads can be disconnected by first installing this tool with a temporary bypass jumper in parallel with the permanent tap connection. After closing the blade of the tool, the permanent tap can be disconnected. The load can then be dropped or reconnected by operating the blade of the tool.

Ratings and Specifications

System Class	Max. Loadbreak Current	Max. Momentary Rating (Amps)	Epoxiglas® Insulation Length
8.3/15kV*	300 Amps	12,000† Asym	6 ³ / ₄ " length
15/27kV*	300 Amps	12,000† Asym	10 ¹ / ₈ " length

* For application on single-phase-to-neutral or three-phase solidly-grounded-wye connected circuits where recovery voltage does not exceed the maximum design voltage of the device.

† This is a pass-through fault current rating only. The tool should never be opened or closed when the current exceeds the maximum continuous load current of 300 amps.

Both Models

Main Line Range		Tap Stud
Minimum	Maximum	
#6 solid copper (0.162")	954 kcmil ACSR (1.20")	1/2" diameter

P6002400
Rev. A

⚠ WARNING

The equipment covered by this instruction guide should be selected, installed and serviced by competent personnel who understand proper safety procedures. This instruction guide is written for such personnel and is not a substitute for adequate training and experience in safety procedures regarding this type of equipment. This guide does not claim to cover all details or variations in equipment nor to provide for all possible conditions to be met with concerning installation, operation or maintenance of this equipment. If further information is desired or if particular problems are encountered which are not sufficiently covered in this guide, contact Chance.

⚠ CAUTION

The equipment covered here is for temporary use only; it is not to be used permanently in place of a cutout or a switch.

⚠ WARNING

Do not close or open this tool on a faulted circuit.

⚠ WARNING

Proper size and rating of the temporary load disconnect tool must be selected for each installation. Should there be any concern regarding use of this tool as rated, consult your supervisor before installation.

⚠ CAUTION

Only qualified personnel should operate a temporary load disconnect tool. Those personnel must wear appropriate protective equipment such as rubber gloves, hard hats, safety glasses, etc. in accordance with established utility and safety practices.

Installation

Remove blade from the temporary load disconnect tool.

Do not proceed with blade in the temporary load disconnect tool.

Do not exceed load current rating of 300 amps.

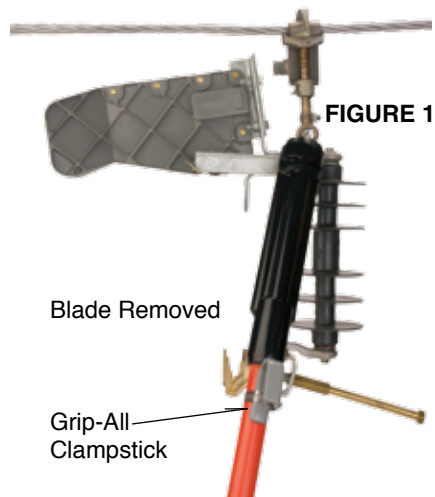

FIGURE 1

Securely attach **both** clamps of a suitable temporary jumper onto the tap stud on the lower hinge.

With the blade **removed**, use a Grip-All clampstick to install the tool securely on the energized line conductor (see (Figure 1). Mount the assembly vertically and allow for clearance above and below the tool to adjacent phase conductors and grounds.

Again using a Grip-All clampstick, place one of the jumper clamps on the load to be picked up (such as apparatus jumper or branch line). **When attaching jumper to load, do not pull tool out of vertical position.**

With a disconnect stick place the blade in the lower hinge of the tool (see Figure 2).

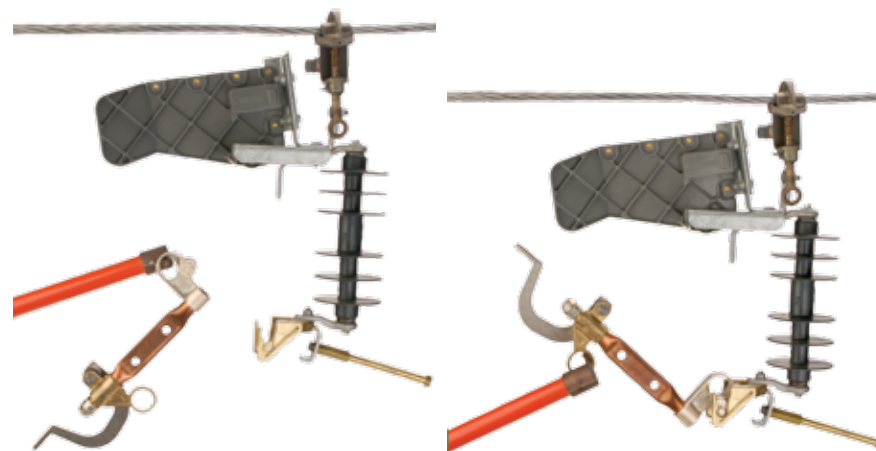

Positioning yourself approximately 2 feet to one side of the tool, place the disconnect stick in the pulling eye and rotate the blade to an intermediate position as shown in Figure 3. Look away from the tool. Quickly and firmly drive the blade into the closed position. Remove the disconnect stick from the pulling eye carefully to avoid opening the blade.

The equipment or circuit is now energized through the temporary load disconnect tool. See following instructions for removing the temporary load disconnect tool.

⚠ WARNING

Hot gases and particles are expelled from the arc chute during opening. These can cause personal injury. Look away and position yourself to the side of the arc chute when opening.